

Sink Specification

Coral 100



Description:

- Modern functional design
- Extra large single bowl with reversible drainer
- Waste outlet in centre of sink
- Suitable for waste disposal unit

Dimensions:

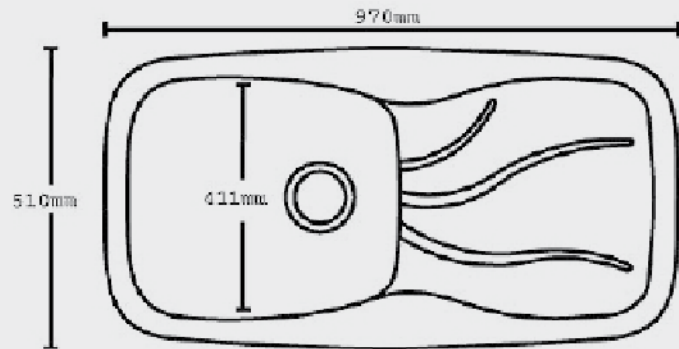

Material:	Granite
Granite Colours:	Cobalt, Green, Slate, Polar White, Natural White, Champagne, Oatmeal, Platinum, Graphite
Application:	Inset
Bowl Size:	460 x 411 x 220mm
Drainer Format:	Not applicable
Cut-out Size:	954 x 494mm
Seal:	Seal to worktop using silicone sealant
Insulation:	Not applicable
Heat Resistance:	Up to 280°C
Earthing Point:	Not applicable

Waste:

1 x Basket Strainer Waste



Overflow:

1 x Overflow



Accessories Available: Chopping board; wire basket

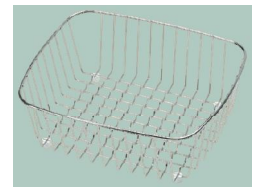

Cabinet Size: Minimum 600mm



Fixing Clips:

8 Supplied

Plumbing Kit supplied:

1 x Pipe Fitting Kit

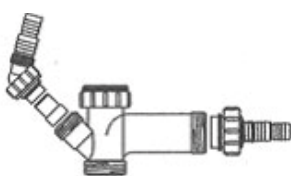

Taps:

Ceramic disc taps in certain installations or where there is a low head of water (below 3 metres) may not provide adequate flow rates. You are advised to check with your supplier.

Guarantee: Carron Phoenix sinks are backed by a lifetime guarantee against manufacturing defects provided the sink is subjected only to normal household use in the kitchen.