

AFTER CARE:

To maintain the appearance of this tap, ensure that it is regularly cleaned only using a clean, soft damp cloth. A solution of warm water and a mild liquid detergent may be used where necessary, and then the fitting rinsed thoroughly and wiped dry. Abrasive cleaners, scouring cleaners and acid cleaners **must not be used** under any circumstances. All bath cleaning powders and liquids will damage the surface of your fitting even the non-scratch cleaners. Avoid contact with all solvents and any harsh household chemicals. You will damage the plated finish and void your guarantee.

GUARANTEE AND LIABILITY

In the unlikely event that you should experience any defect in the material or workmanship of your mixer tap within 5 years of purchase, we will replace the faulty part free of charge. Decorative surface finishes and valves are guaranteed for one year from the date of purchase provided that our advise concerning care has been observed and no scouring agents have been used. This is provided that the mixer or tap has been used for normal domestic purposes in the UK and that the care, installation and maintenance instructions have been observed. Scuff and scratches caused by normal wear and tear, improper installation or accidental damage are excluded from this guarantee. You should retain a copy of your dated invoice as proof of purchase to validate any claims under this guarantee. No other warranties, express or implied, are made, including merchantability or fitness for a particular purpose.

SPARE PARTS AND SERVICE

Contact
Phone
Fax
e-mail
web-site

CARRON PHOENIX
01324 638321
01324 611962
sales@carron.com
www.carron.com



OSPREY

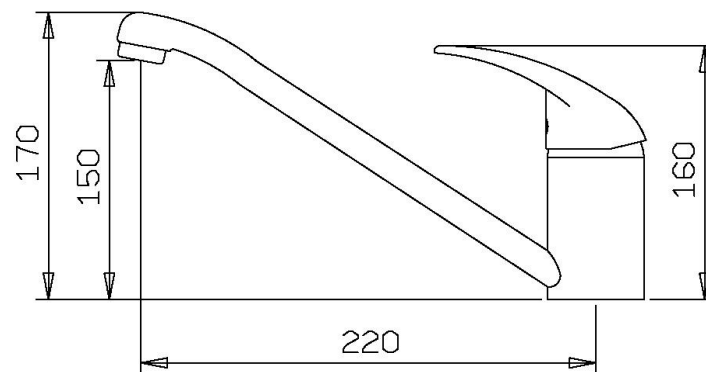

Fitting Instructions & Contents List

Please keep these instructions for future reference and request of replacement parts.

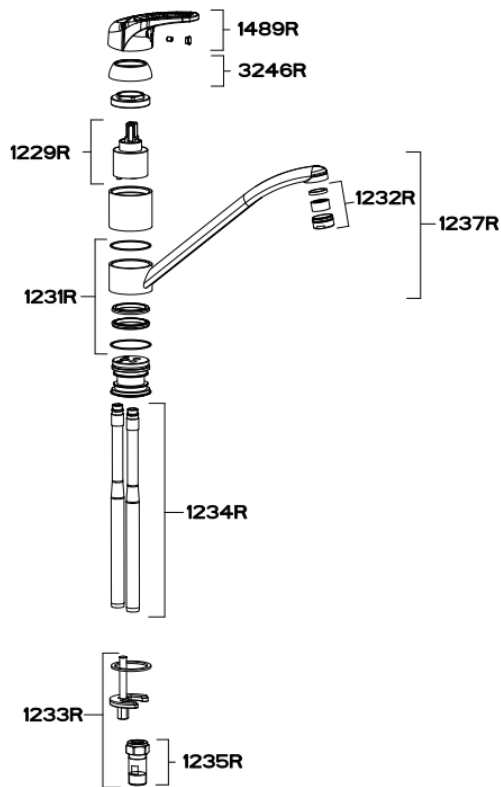

<u>CODE</u>	<u>DESCRIPTION</u>
1232R	Antisplash
1237R+color	Spout
1489R+color	Handle
3246R+color	Dome
1229R	Cartridge
1231R	O-ring kit
1233R	Fixing kit
1234R	Tail pipes
1235R	Non return valve

Please read these instructions before you install and use the tap. All designs, descriptions and dimensions are subject to change without notice.

Preparation

Flush the plumbing system before installing the mixer tap. This is to avoid plumbing residues clogging the mesh of the aerated outlet, or possibly damaging the ceramic cartridge. This is especially important where extensive plumbing work has been carried out.
 First shut off your water heating system then, with your mains stop cock closed, open the lowest hot and cold taps in the house and allow to run until the cold storage tank and pipes are empty. (The hot water storage cylinder always remains full).

Installation

- First screw the threaded stud into the mixer body. Screw the copper tubes into the mixer body, and fully hand tighten.
- Pass the rubber washer over the copper tubes and threaded stud to form a seal on sink top.
- Pass the copper tubes and fixing stud through the sink top from above, and place the mixer in position on the sink with the cold (blue) and hot (red) located correctly. Cold on the right and hot on the left port.
- Slide the retaining plate up the copper tubes, screw the fixing nut finger tight. Check that the mixer body is correctly positioned and fully tighten fixing nut.
- The copper tubes at this stage will need to be gently turned outwards, then supported approximately half-way down and turned inwards, making the two pipes parallel again but further apart thus making room for the couplings to be fitted. It is recommended that 15mm x 15mm compression fitting be used to connect mixer to supply pipes.
The use of capillary fittings could invalidate your warranty.
- Having first checked all new connections, turn on the mains stop cock, close all taps except the new mixer and as the system starts to refill check for leaks.

In the unlikely event you find a part missing please contact our Customer Service Help line on 01324-638321 for immediate dispatch of part.

Remember:

Maximum water supply pressure: 75 PSI (5 bar)
 Maximum hot-water supply temperature: 70 °C
 Recommended hot-water supply temperature: 65 °C

If these temperatures or water pressure are exceeded damage to the tap can result. A pressure reducing valve may be required to be fitted in high water pressure situations.

Where an aerator is fitted to the outlet of the spout, it will need occasional cleaning. This will be evident when the water flow slows down to an unacceptable level. To accomplish this unscrew the outlet in an anti-clockwise direction and remove the mesh. Immerse the mesh in a suitable descaling fluid overnight, rinse thoroughly in clean water and re-install.

N.B. This mixer is supplied with a single check valve which should be used on the hot supply when the mixer is fitted to unbalanced supplies to prevent backflow i.e. Cold from the mains and hot via a hot water cylinder.